

# GAS COMPRESSORS

your gas compression solution



Model SSMG99B

Gardner Denver rotary screw gas compressors incorporate design features that meet the demands for efficient, flexible, durable operation placed on them by the Natural Gas Industry.

## DESIGN FEATURES

- O-ring flange seals.
- Large rotors and bearings for low speed operation.
- Cylindrical roller inlet bearings.
- Tapered roller discharge bearings.
- Automatic Turn Valve capacity control.
- Stop-limits for fully opened and fully closed turn valve positions.
- Turn Valve indicator standard on Turn Valve-equipped gas ends.
- 3 Axis vibration pick-up points.
- Available frame-mounted oil pump.
- Available vertical or horizontal inlet valve.

## ENGINEERING DATA

Brake Horsepower	135 Max.
Inlet Pressure	50 PSIG Max.
Discharge Pressure	375 PSIG Max.
RPM Range	742 - 3245
V <sub>i</sub> 's Available	1.8; 2.2; 3.0; 5.2
Rotor Dimensions	
Male Rotor O.D.	8.1"
Female Rotor O.D.	7.5"
Length	13.5"
L/D Ratio	1.66
Input Shaft	
O.D.	1.7490" - 1.7495"
Keyway	0.375 in
Stiffness	3.07 x 10 <sup>6</sup> in*lb/rad
Moment of Inertia ("ωr <sup>2</sup> ")	7.24 lb*ft <sup>2</sup>
Mounting Flanges Available	
	SAE (3)
	"C" Flange
	"D" Flange
	Plain (Foot) Mounting
Discharge Flanges Available	
	2.5" 150#
	2.5" 300#
Inlet Valve Flanges Available	
	5" 150# Vertical
	4" 150# Horizontal
Weight Approx.	670#
Materials	
Rotors	Nodular Iron
Bearings	Steel
Frame	Cast Iron
Shaft Seals	Mechanical
Oil Pump (0 PSI, 1800 rpm, 200 SSU)	
Capacity	37 GPM
Horse Power	1.2 HP

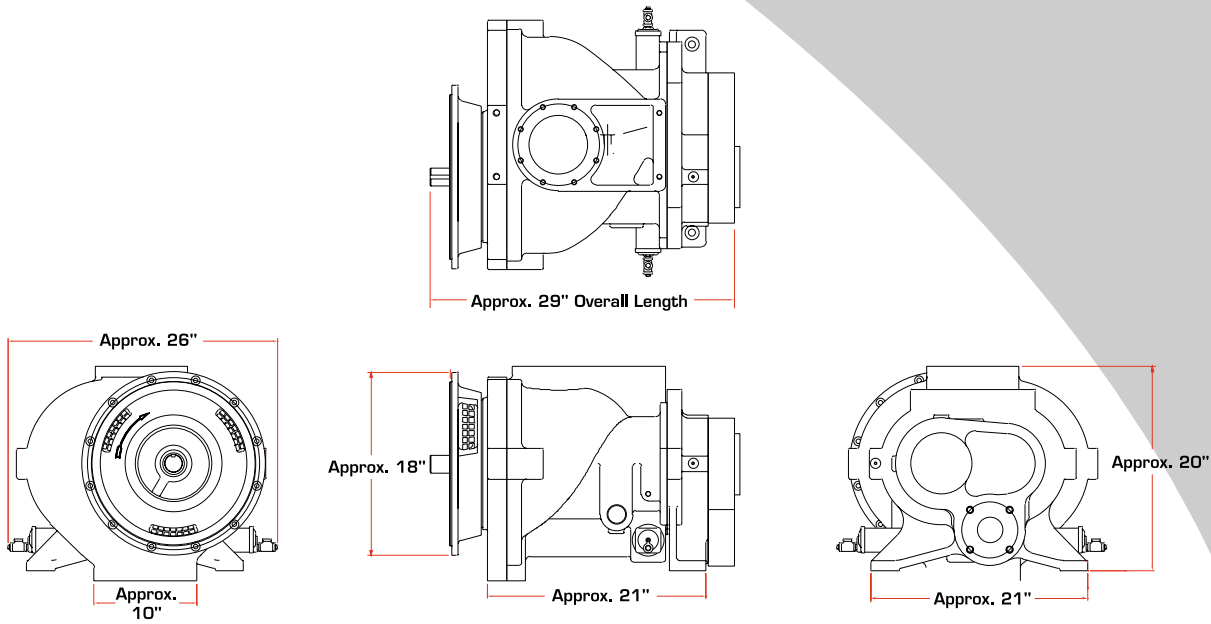

## DURABILITY MEASURED IN DECADES

Since 1859, Gardner Denver has designed and built the industry's highest quality products. To better serve your needs, Gardner Denver continually builds products to maximize efficiency and durability. Our rotary screw compressors for natural gas applications are no exception to this tradition. Gardner Denver rotary gas compressors are constructed using advanced technology, careful engineering, micro-precision manufacturing, and total quality management. These inherent features make Gardner Denver the choice when reliability and total value are the criteria.

### Natural Gas Applications

Gardner Denver rotary screw gas ends are well suited for natural gas compressor applications. All Gardner Denver gas compressors are constructed of ferrous metal. No yellow metals are used in the gas end construction. This allows the Gardner Denver Rotary Gas Compressor to be used in virtually any natural gas application.

## PREMIUM FEATURES

Gardner Denver offers more features per horsepower, more features for your dollar, more options to match your job, and more efficiency to save on your power costs. The savings of owning and operating a Gardner Denver Rotary Gas Compressor begin to build the minute you turn it on - and keep building throughout its long, productive life.

### Exclusive Gardner Denver Features

All Gardner Denver Rotary Screw Compressors contain a unique combination of outstanding features:

- Exclusive KYPHO rotor profile returns greater efficiency over its operating range and delivers a 3% to 5% operating efficiency advantage over standard rotor designs. Its asymmetrical rotor shape inherently provides a tighter seal between the grooves of the rotors to reduce slippage, eliminate vibration, and increase efficiency.
- Rotors, up to 41% larger in diameter than other compressor brands, allow our rotor operating speeds to be among the lowest in the industry. Low speeds extend compressor life, reduce compression heat and contribute to overall lower operating cost.
- Long-life bearings mean longer service. Gardner Denver SSM gas compressors are designed with large, cylindrical roller bearings at the inlet and time-proven tapered roller bearings at the discharge. Gardner Denver uses bearings as much as 170% larger than competitive models.
- Standard features, such as tapered roller bearings and vibration pick-up points, as well as available options such as oil pumps and inlet valves, give Gardner Denver gas compressors the versatility to match your demanding application.



**Gardner  
Denver**

